

Agata Augustine

Interior Designer & Artist

AKBD, CLIPP | Kohler Design Center

Where My Creative Journey Began

I introduce myself as an artist first — creativity is my foundation.
Early on, I experimented with drawing, painting, and set design.

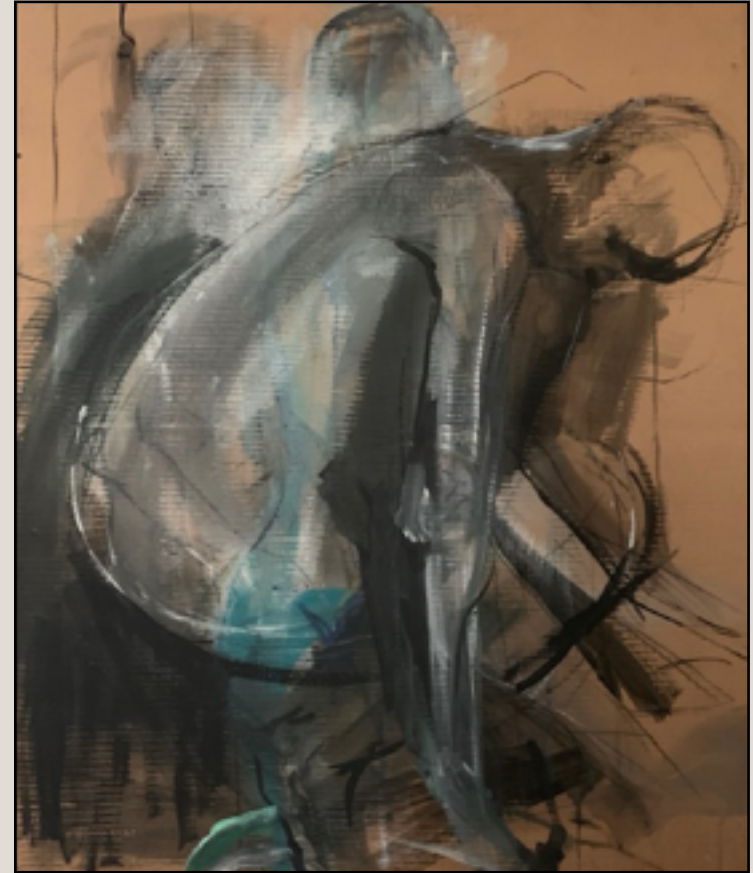

From Canvas to Movie Set: Creating For Film

Worked on several movie set designs, including the 2007 Oscar-winning animated short, “Peter and the Wolf.” Set work taught me storytelling, scale, and collaboration on tight deadlines.



Designing Spaces: From Luxury Furniture to Interiors

After moving to the U.S., I joined Baker Furniture— a luxury furniture brand — as a sales representative who also designed interiors. Sketching scenes for clients was the spark that launched my interior design career.



Kohler Design Center: Where Ideas Become Plans

Transitioned to an Interior Designer Position at Kohler Design Center after Baker was sold. My process is hands-on. I draw and write as I brainstorm to explore multiple options quickly.

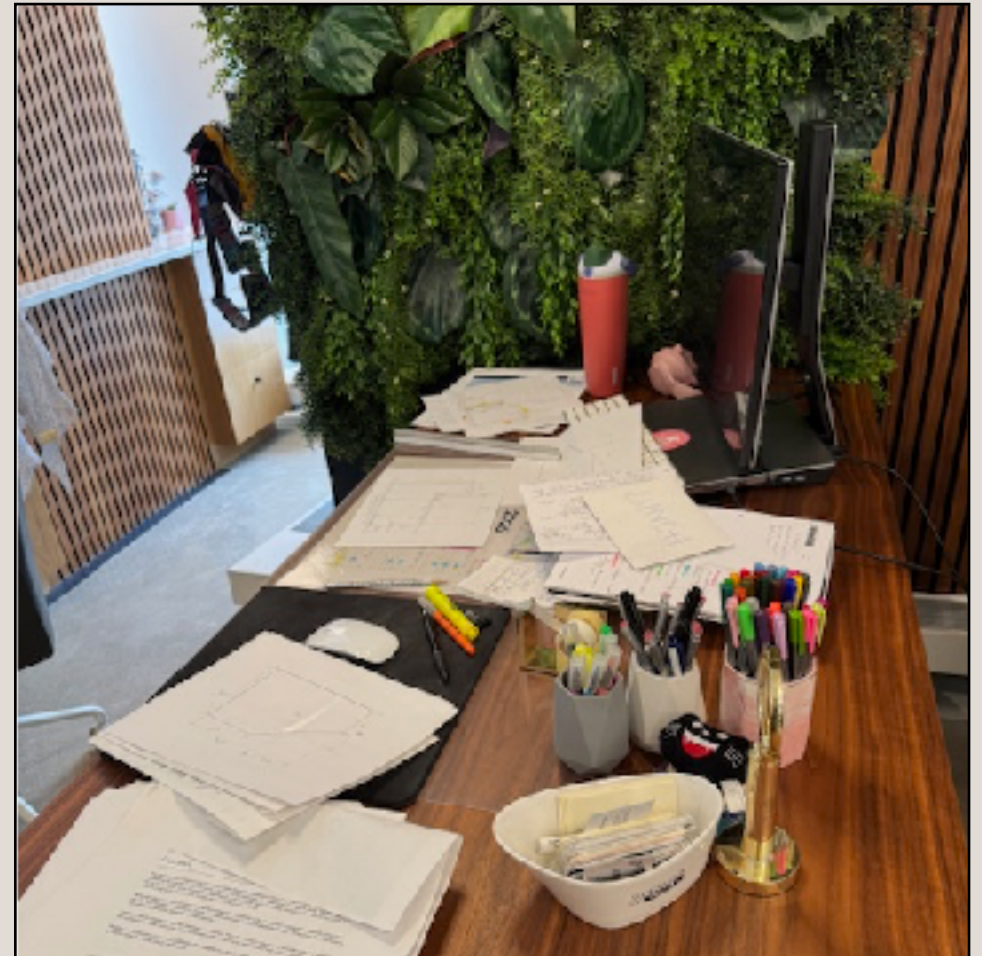

Why I Start Drawing By Hand: Accuracy + Imagination

I draw floor plans to scale by hand first to fully visualize the room. Drawing keeps measurements accurate and quickly reveals what will or won't fit.

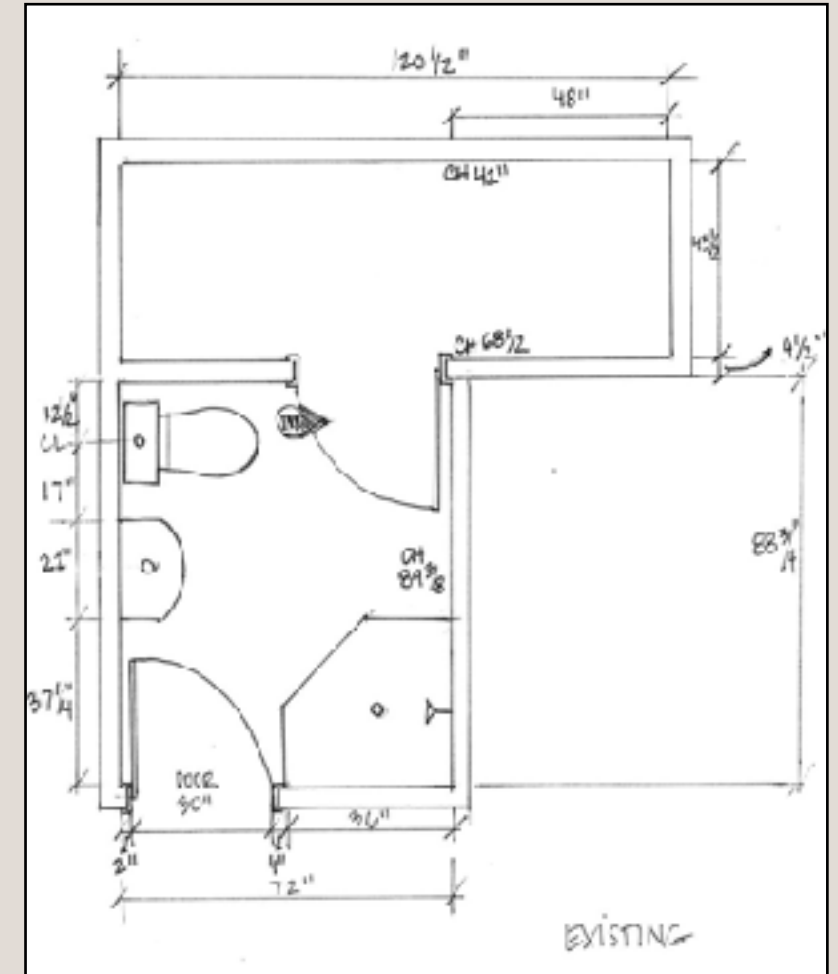
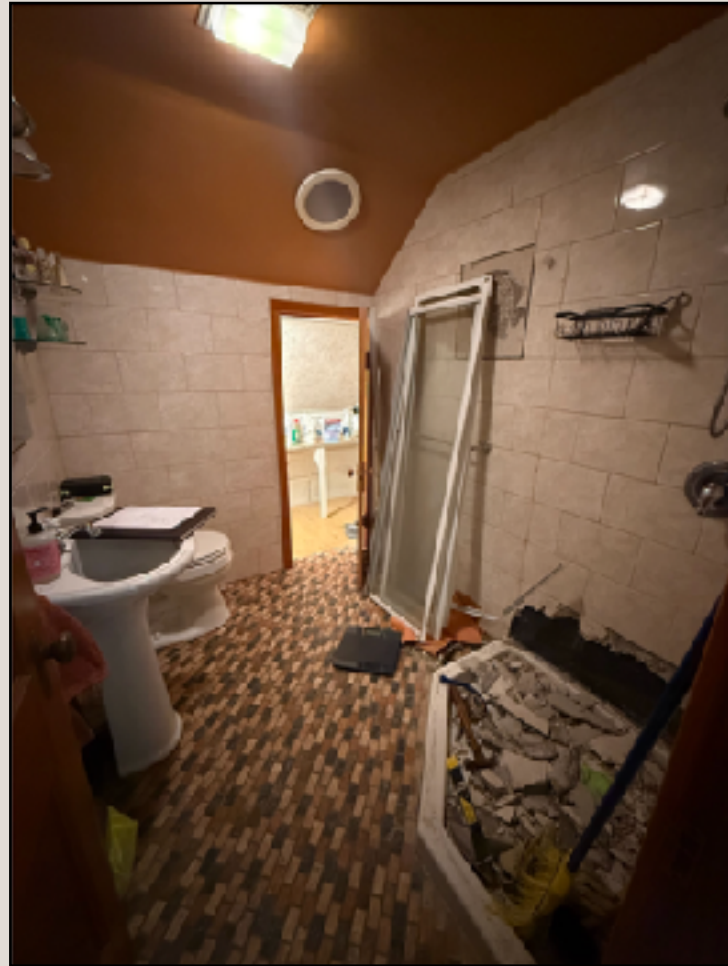

Small Rooms, Smart Choices

In tight spaces or with sloped ceilings, the simplest solution is often best.
Good design prioritizes function, light, and storage.

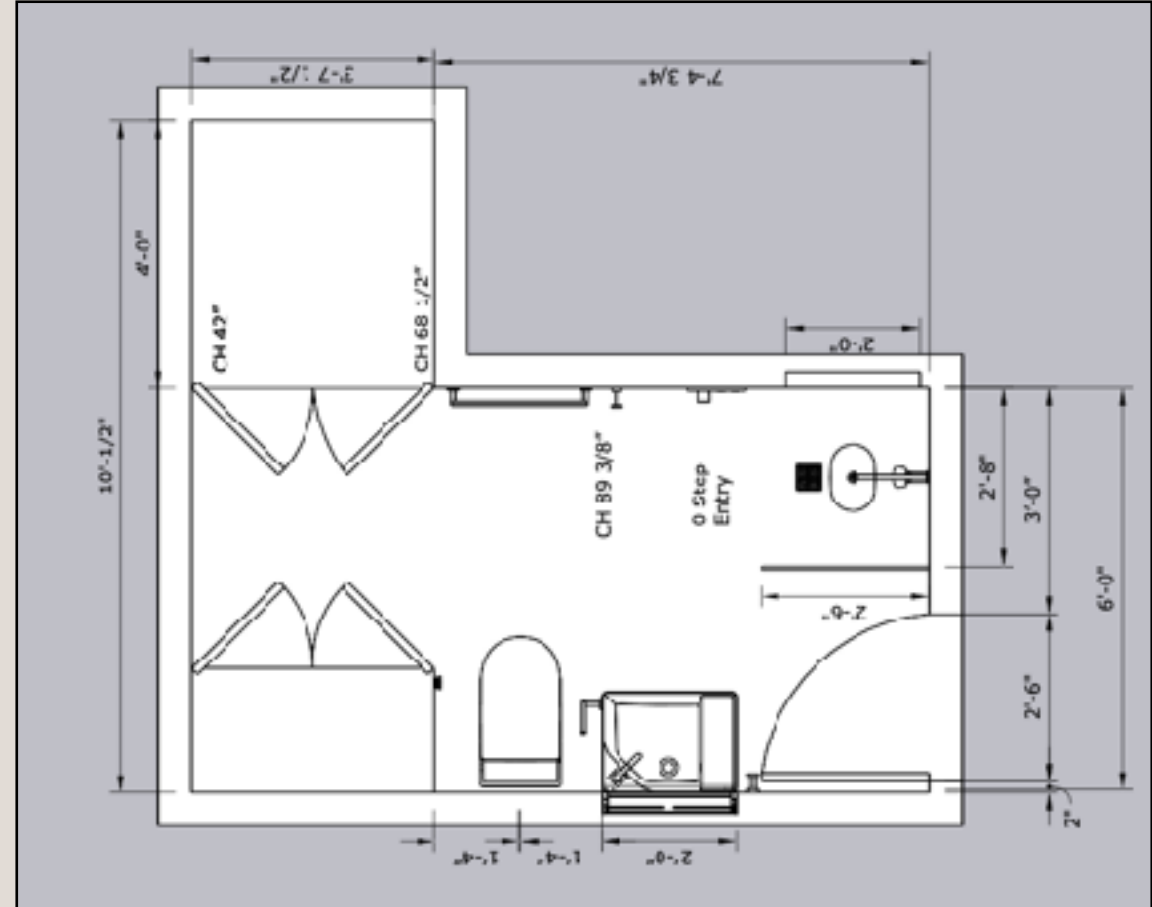

Result: Light, Airy, Multi-Functional

Maximized storage, smart showering, and dual-purpose fixtures.
A reminder that constraints can inspire creativity.

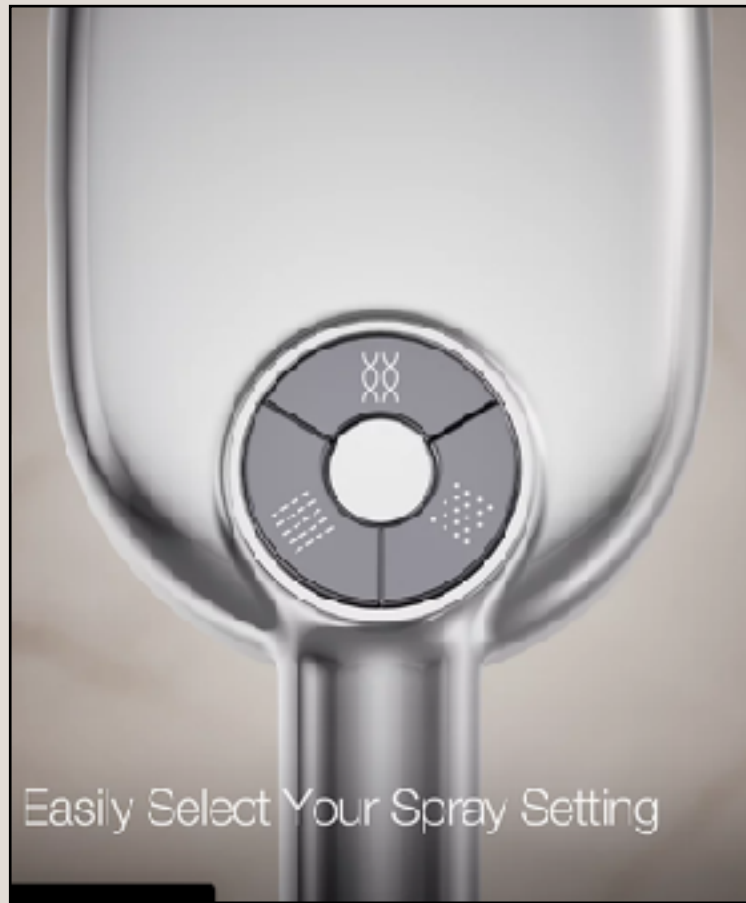

From Wish List to Build Sheet

A client brought 27 “must-have” items for a new home. My job: specify Kohler products that perform correctly, include all technical parts, look beautiful, and meet budget. Best part: reducing decision anxiety during a stressful build.

	<u>Kitchen</u>	<u>Utility Room</u>	<u>Powder Room</u>	<u>Master Bathroom</u>	<u>Bedroom #2</u>	<u>Bedroom #3</u>
Sink	N/A	??		??		
Faucet						
Toilet	N/A	N/A				
Shower	N/A	N/A	N/A			N/A
Tub	N/A	N/A	N/A		N/A	N/A
Tub Faucet	N/A	N/A	N/A		N/A	N/A
Tub Drain	N/A	N/A	N/A		N/A	N/A
Shower/Tub Combo	N/A	N/A	N/A	N/A	N/A	
Shower Head/Body Spray	N/A	N/A	N/A			
Shower Drain	N/A	N/A	N/A			

peter/kohler
asa 12/06/25

27 ITEMS

Core Skills For Interior Designers

- **Reading complex floor plans and construction documents.**
- **Deep product knowledge (Kohler and beyond).**
- **Tracking trends across interiors, materials, and technology.**
- **Problem-solving under constraints.**
- **Creativity: curating selections that look cohesive at any budget.**
- **Empathy, the ability to connect with different people.**



Beyond Client Work: Concept and Exhibit Design

Developed proposals to refresh mezzanine rooms at the Kohler Design Center.
Recent concept: Gen Z Maximalism — bold color, layered patterns, and playful contrast.



Sharing Knowledge at KBIS

Represented Kohler Design Center at KBIS, the industry's largest North American trade show. Our success opened opportunities for more Kohler Design Center associates to share product expertise each year.



Stretch Projects that Keep Us Growing

**Partner with influencers and public figures on home projects.
Support Kohler donation initiatives and special installations.
Occasionally, design unique product displays to tell a story.**

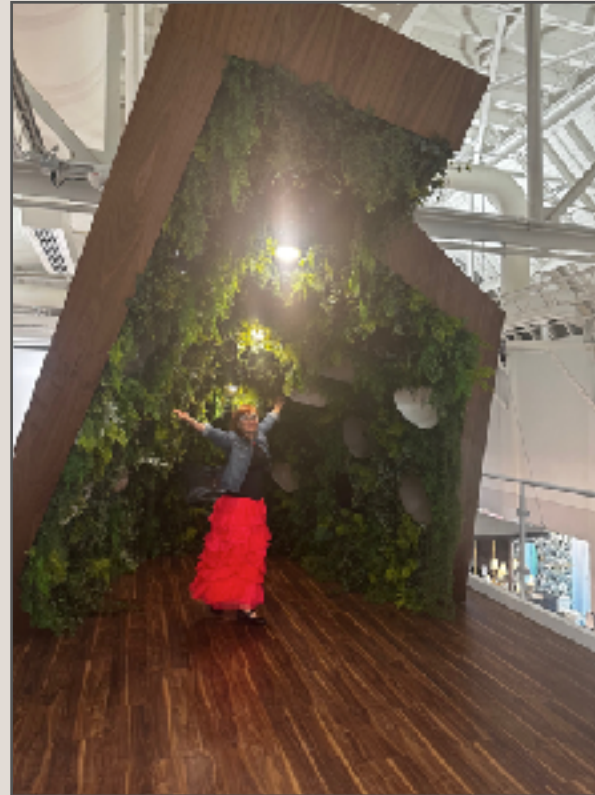

Thank you